

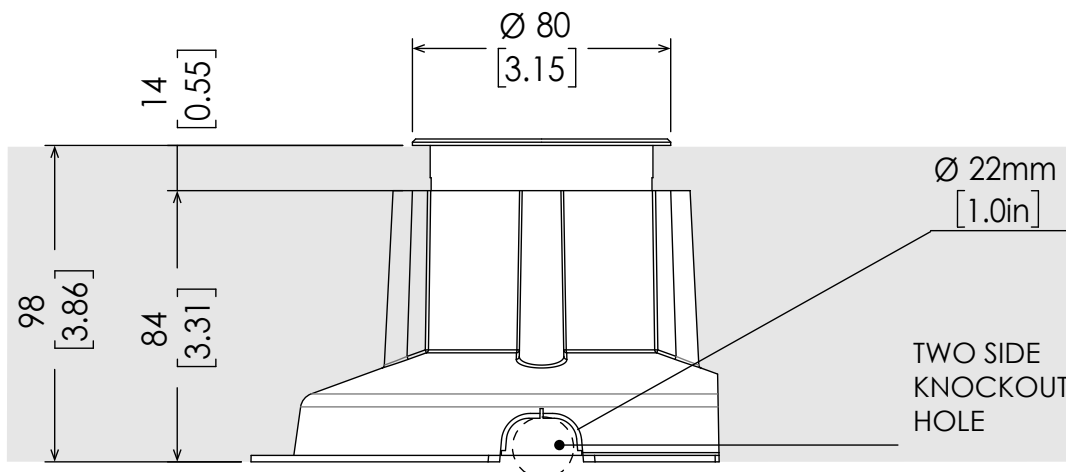

Code / Codice	AL5311		
	Moon Recessed W		Moon Recessed RGBW /DW
	SP/NA/ME/WI/EW	ULTRASPOT	
Power consumption Consumo di energia	8W MAX	3W MAX	4,6W MAX
Remote Power supply Alimentatore Remoto	Constant Current: 250 mA	Constant Current: 800mA	Costant Voltage: 24 Vdc
Foward voltage	35 V	3 V	
Electrical class Classe elettrica			
Weight / Peso	0,9 Kg / 2 lb		
Operating temperature Temperatura di funzionamento	-40°C to 40°C / (-40°F to 104°F)		
IP rating / Grado IP	IP65/ IP68 -1,5m		
IK rating / Grado IK	IK09 ALL GLASS and FRAME / IK10 DRIVEOVER		
Maximum surface temperature allowed / Massima temperara Superficiale amnessa	62°C / 144 °F		
Maximum static load / Massimo Carico Statico	19.620 N		

Size / Dimensioni

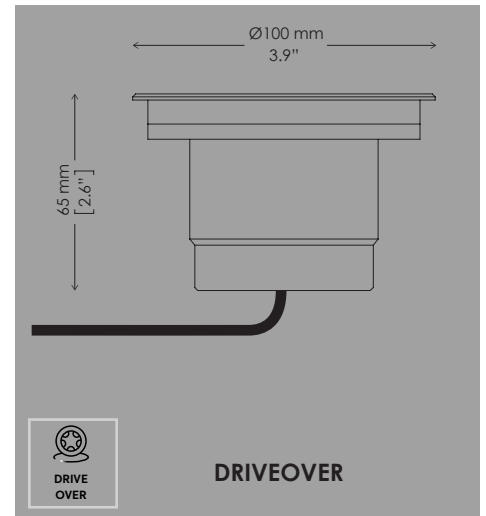
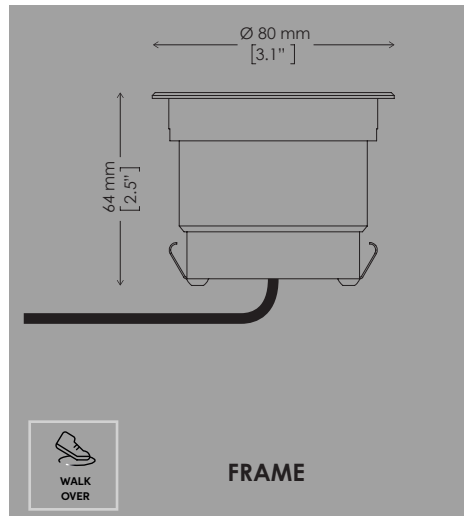
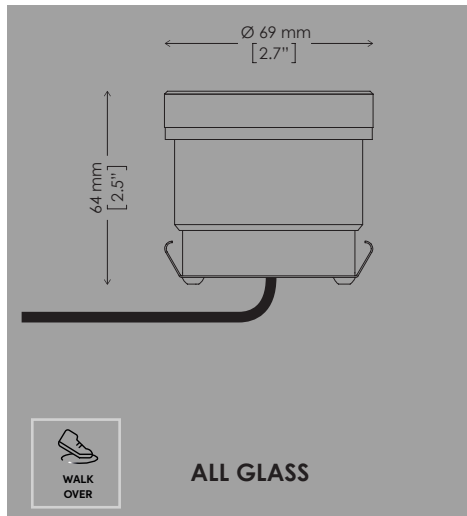

Important notices - Avvisi importanti

- This product must be installed in accordance with applicable national and local electrical and construction codes by a person familiar with the construction and operation of the product and the hazards involved. Failure to comply with the following installation instructions may result in death or serious injury.

Questo prodotto deve essere installato secondo le normative locali, da personale specializzato. La mancata osservanza delle istruzioni di installazione può portare a situazioni di pericolo all'incolumità della persona.

- Do not stare at the operating light source.

Non fissare la sorgente luminosa durante il suo funzionamento.

- The fixture might be damaged by excess voltage. The installation of an overvoltage protection device on the electrical system may reduce the risk of damage.

Apparecchiatura sensibile alle sovratensioni. L'installazione di un dispositivo di protezione delle sovratensioni sull'impianto elettrico attenua l'intensità di questi fenomeni proteggendo gli apparecchi dal rischio che vengano danneggiati.

- The use of an adequate magnetothermic switch along the power supply line is recommended.

E' consigliato l'uso di un adeguato interruttore magnetotermico/differenziale sulla linea di alimentazione.

- Connect the fixtures to each other only when disconnected from mains.

Collegare tra loro i proiettori solo quando nessuno di essi è collegato alla rete elettrica.

- Never leave cables and connectors unconnected or unprotected for long periods.

Non lasciare mai per lungo tempo agli agenti atmosferici cavi e connettori non collegati o non protetti.

- Disconnect power before installing or servicing to avoid electrical shock.

Togliere l'alimentazione prima di effettuare qualsiasi operazione all'interno dell'apparecchiatura.

- Disconnect power before any connection operation.

Togliere l'alimentazione prima di effettuare qualsiasi operazione di connessione tra gli apparecchi.

- Check voltage and frequency before powering the fixture. Do not exceed fixture specified voltage.

Prima di connettere l'apparecchio alla rete elettrica, verificate la compatibilità di tensione e frequenza.

- Do not handle the unit with wet hands or in wet environments.

Non maneggiate il prodotto con mani bagnate o in presenza di acqua.

- Apply to qualified staff for any maintenance service not described in this instructions manual.

Rivolgersi ad un tecnico qualificato per qualsiasi operazione di manutenzione ordinaria non descritta nel presente manuale.

- Do not exceed the maximum quantity of fixtures per line in order to avoid power surges.

Non superare il numero massimo specificato di apparecchi per linea per evitare pericoli di sovraccarichi di corrente.

- Before powering the unit, ensure to use cables and connectors with proper section and length, according to its power consumption.

Prima di effettuare le connessioni verificare la portata dei cavi / connettori e la lunghezza dei cavi tenendo conto dell'assorbimento del prodotto.

- Fix the projector by using screws, hooks or other adequate supports that can bear its weight.

Fissare il proiettore con viti, ganci o altri supporti in grado di sostenerne il peso.

- All devices connected to the DALI bus must be SELV type.

Tutte le apparecchiature connesse al bus DALI devono essere di tipo SELV.



CAUTION: Prolonged staring at the LED source should be avoided by placing the fixture in a proper position.



WARNING ! Fixing and connecting operations must mandatorily be carried out by qualified personnel only !



WARNING ! Make sure that power supply is off before connecting or disconnecting fixtures !

The possibility of reusing some electrical parts of the device is subject to the total responsibility of the user. The label shows the symbol indicated in Legislative Decree n.49 of 14 March 2014 which transposes Directive 2012/19 / EU, which indicates the need to dispose of the product in separate waste, specifically in electrical waste. and electronic. Refer to the waste collection center located in your area.



The light source in this luminaire may only be replaced by the manufacturer or its service department



La sorgente luminosa contenuta in questo apparecchio deve essere sostituita solo dal costruttore o dal suo servizio di assistenza



The external flexible cable or cord of this luminaire cannot be replaced; if the cord is damaged, the luminaire shall be destroyed.

Il cavo o i conduttori esterni di questo apparecchio non possono essere sostituiti; se il cavo è danneggiato l'apparecchio sarà smaltito.

Installation - Installazione

SOLID SOIL in concrete - Prearrange an adequate support for the formwork as well as a drainage system through a pipe that allows the water to flow without creating stagnations.

TERRENO SOLIDO in cemento - Predisporre un adeguato supporto alla cassaforma ed un drenaggio attraverso un tubo che permetta all'acqua di drenare senza creare ristagni.

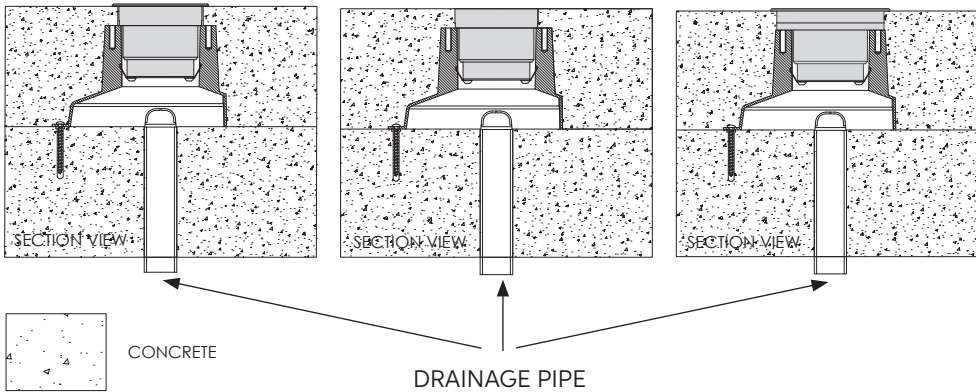

SOFT SOIL - Arrange an adequate water drainage system with pebbles.

TERRENO MORBIDO - Predisporre un adeguato drenaggio con ciotoli per il drenaggio dell'acqua.

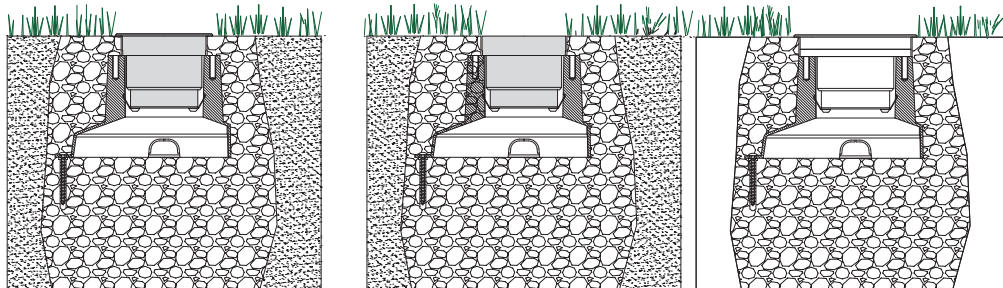
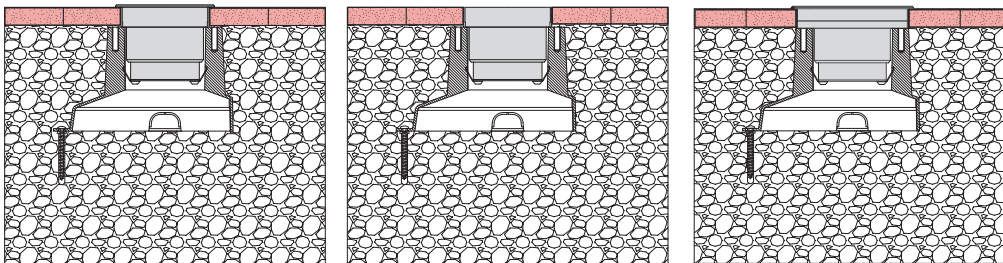

INCORRECT INSTALLATION
INSTALLAZIONE NON CORRETTA

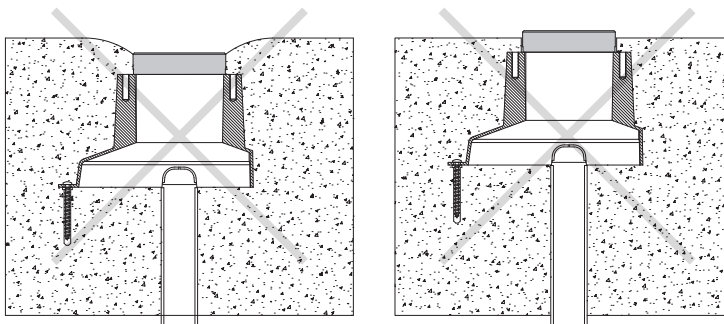

Open the formwork on one side for the passage of the corrugated pipe. If necessary, also open it on the other side.

Rimuovere dalla cassaforma il primo tassello per il passaggio del tubo corrugato. Se necessario rimuovere anche il secondo tassello.

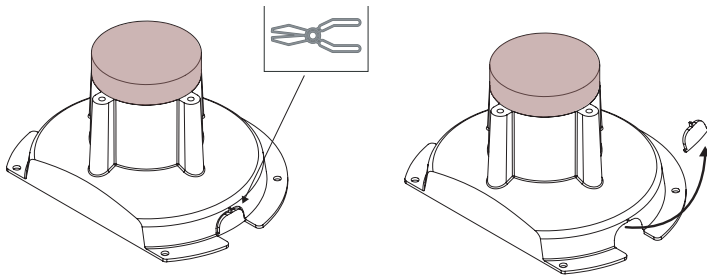

Insert the pipe into the formwork and then fix it to the ground through the specific fixing holes.

ATTENTION: Point the flat side of the formwork towards the wall as shown in the image below.

Posizionare il tubo corrugato nell'apposita apertura ricavata nella cassaforma e successivamente fissare la cassaforma al terreno utilizzando gli appositi fori di fissaggio. ATTENZIONE Orientare la faccia piana della cassaforma parallelamente al muro come indicato nell'immagine.

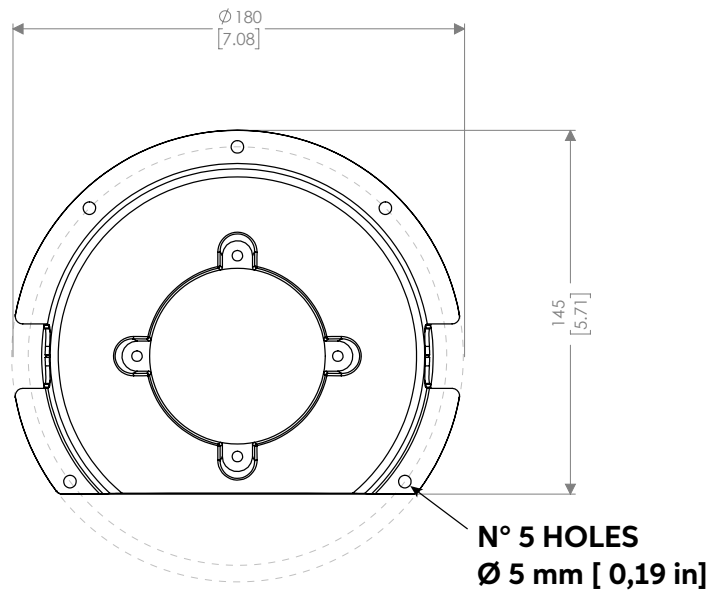
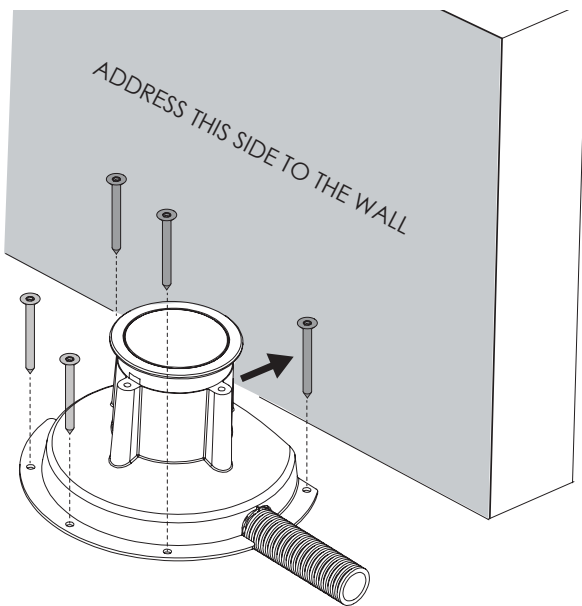

ATTENTION: pour cement up to the level of the cap.

ATTENZIONE: versare il cemento fino al livello del tappo.

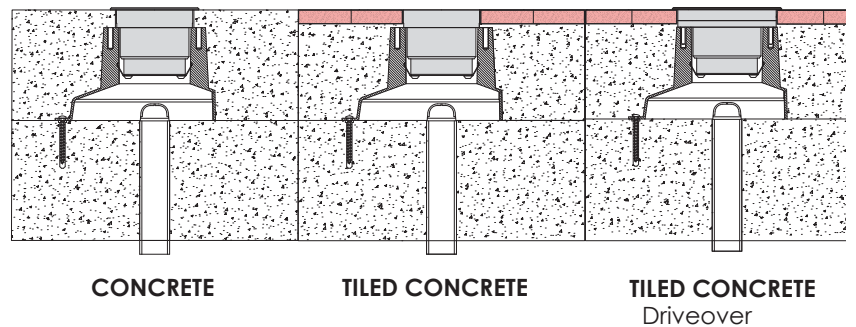
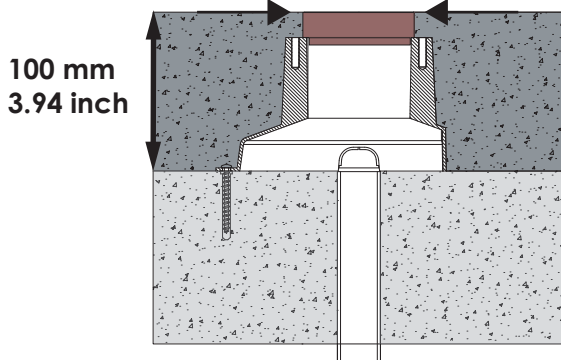

ATTENTION: To facilitate the removal of the cap, its recommended to use a release agent for formworks.

ATTENZIONE: Per facilitare l'estrazione del tappo si consiglia di utilizzare un agente distaccante per cassaforme.

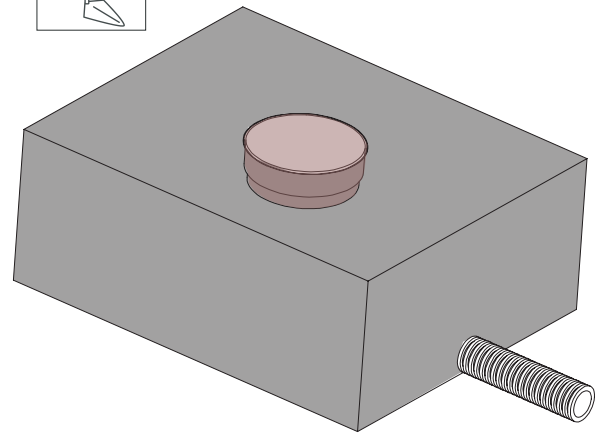
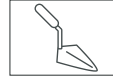
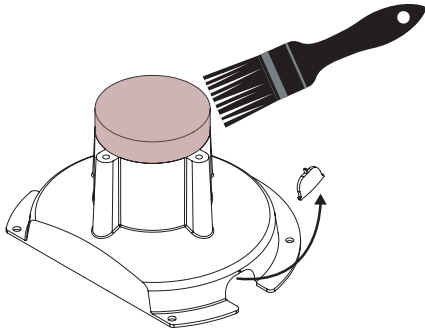

Fill with cement up to the level of the cap and clean off any material in excess that may prevent the removal of the cap

Riempire con cemento fino al livello del tappo e rimuovere l'eventuale materiale in eccesso che possa impedire la rimozione del tappo.

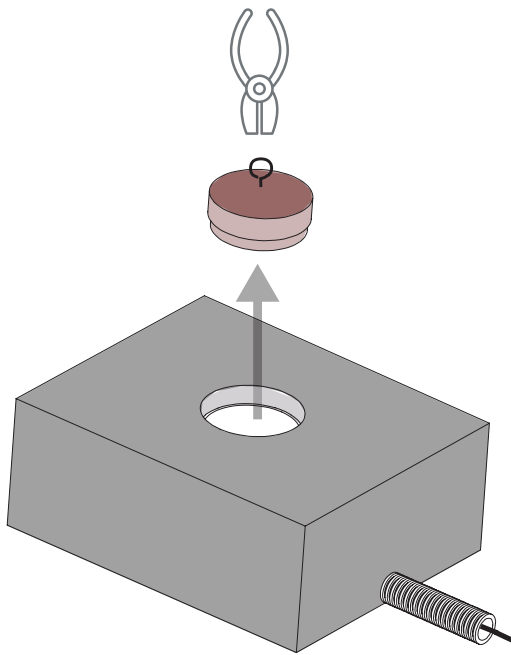

Before installing the fixture, remove the cap from the formwork by using pliers.

Prima di iniziare l'installazione dell'apparecchio rimuovere il tappo della cassaforma. Facilitare l'operazione aiutandosi con una pinza per imprimere maggiore forza.

INCORRECT INSTALLATION

INSTALLAZIONE NON CORRETTA

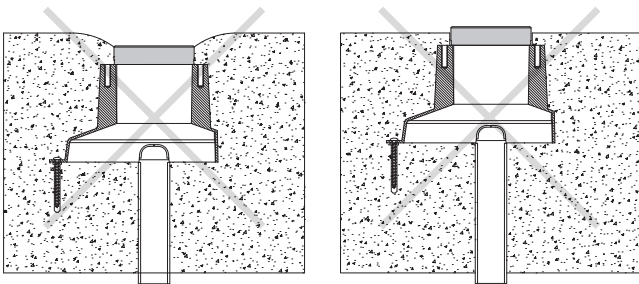

Connect the fixture to the power cable. Put the heat shrink tube fitted with glue "1" on the power cable. Connect to the mains through the connectors "2", pressing them with the appropriate tool "3". Heat the tube using the heater "4" until it completely shrinks. This connection will feature an IP67 protection degree.

Connettere il proiettore al cavo di alimentazione. Inserire la guaina termorestringente con collante "1" sul cavo di alimentazione. Effettuare il collegamento alla rete tramite i connettori testa - testa "2", premendoli con l'apposito attrezzo "3". Riscaldare il tubo utilizzando un riscaldatore per tubi termoretraibili "4" fino a completo restringimento. La connessione così ottenuta ha un grado di protezione IP67.

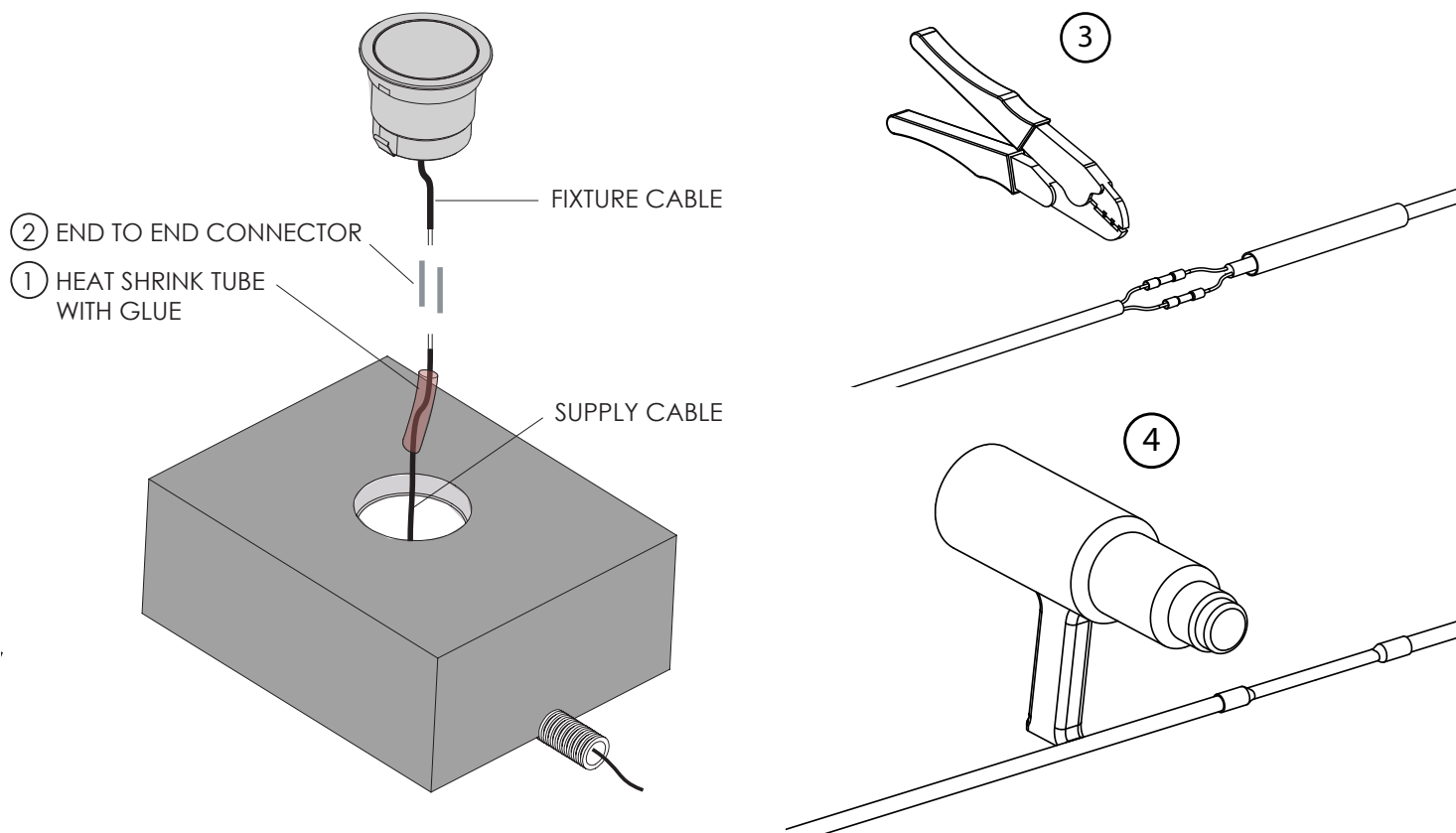

When connected, roll up the cable inside the formwork and put the fixture into the formwork itself.

Dopo aver effettuato le connessioni arrotolare il cavo all'interno della cassaforma e posizionare l'apparecchio all'interno della cassaforma.

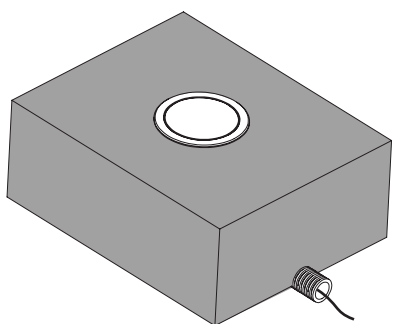
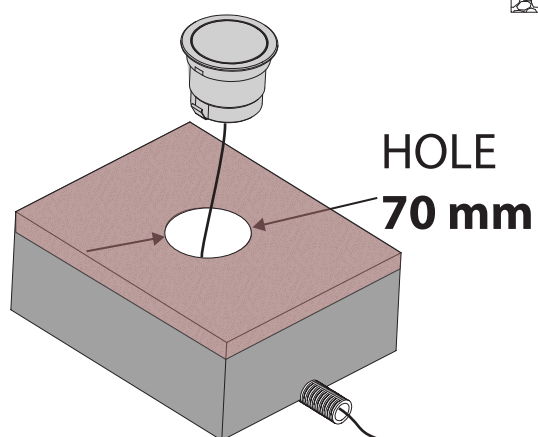
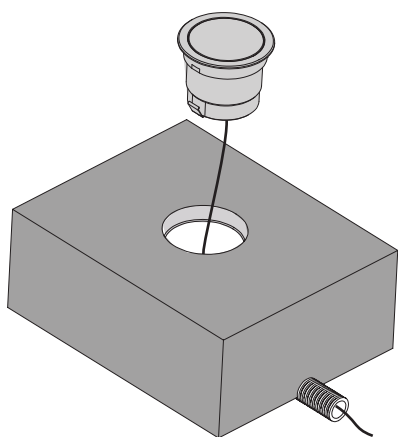
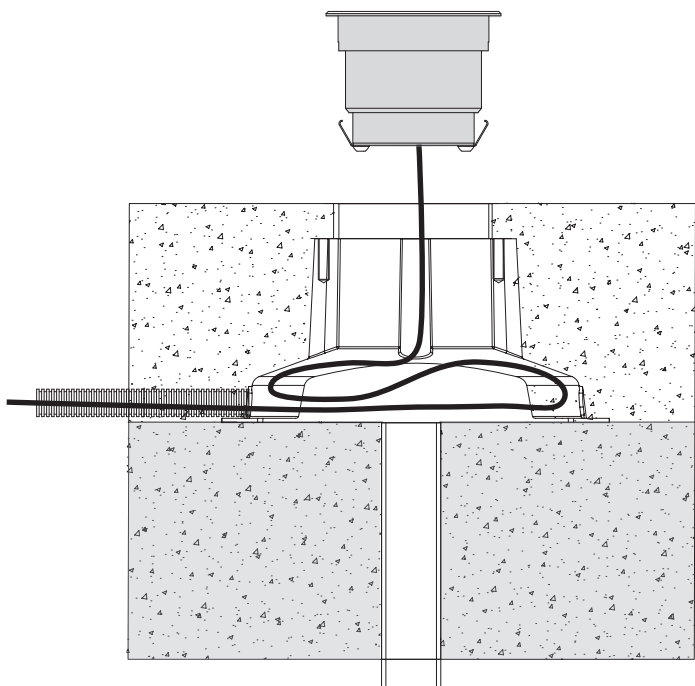

MINIMUM **1** FIXTURE MAXIMUM **3** FIXTURE
 Distance between PSU and the last fixture: **20** meters

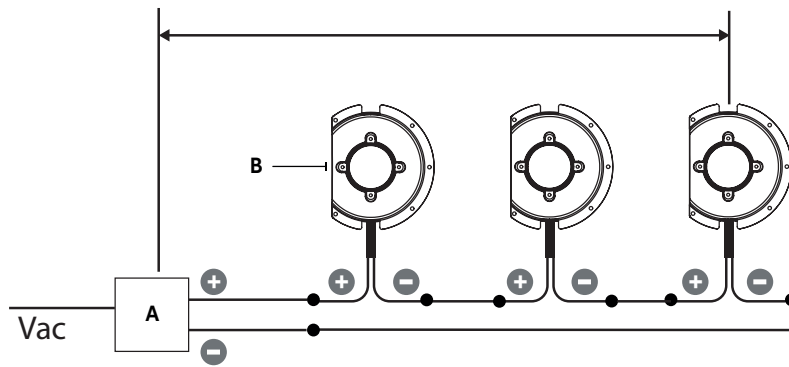

CABLE/CAVI	USE/UTILIZZO
RED / ROSSO	V+
BLACK / NERO	V-

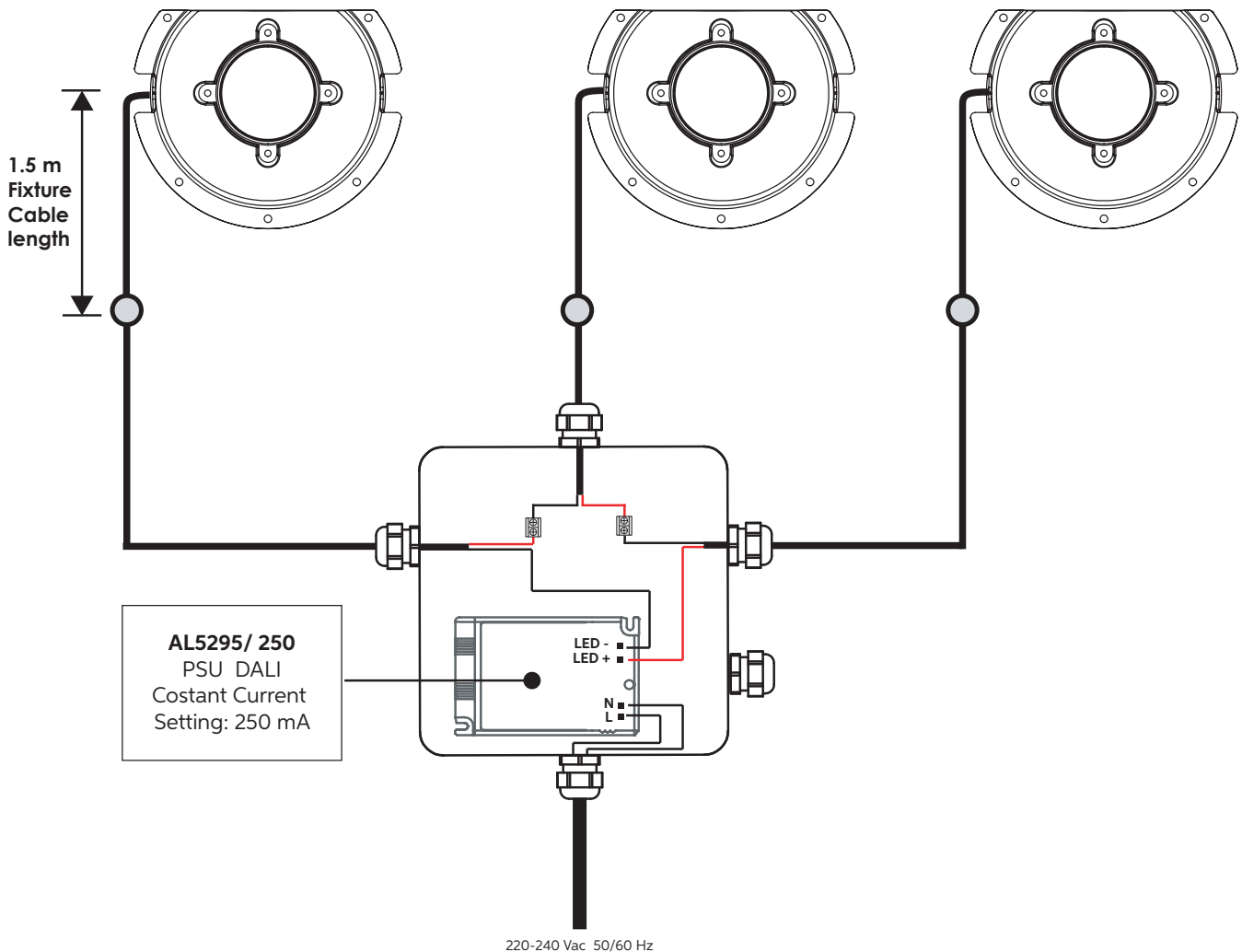

MINIMUM 1 FIXTURE MAXIMUM 8 FIXTURE
 Distance between PSU and the last fixture: **42 meters**

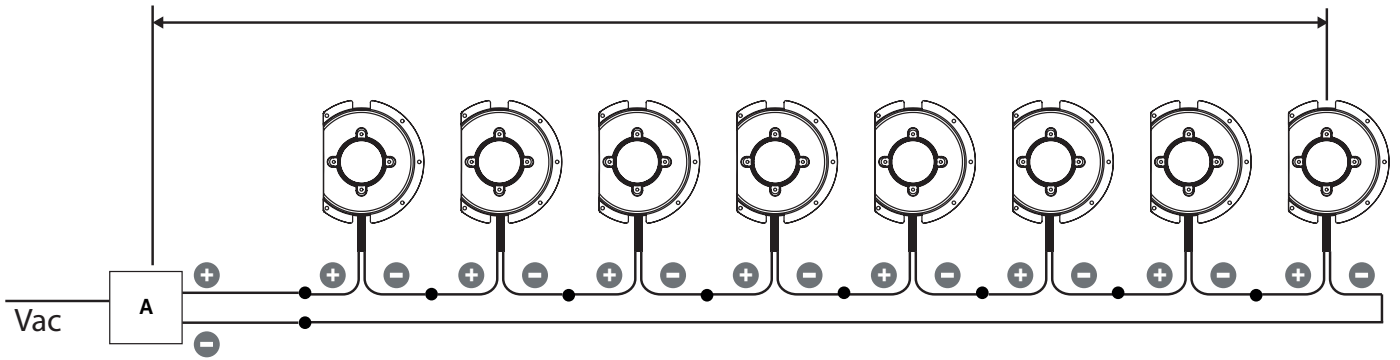

CABLE/CAVI	USE/UTILIZZO
RED / ROSSO	V+
BLACK / NERO	V-

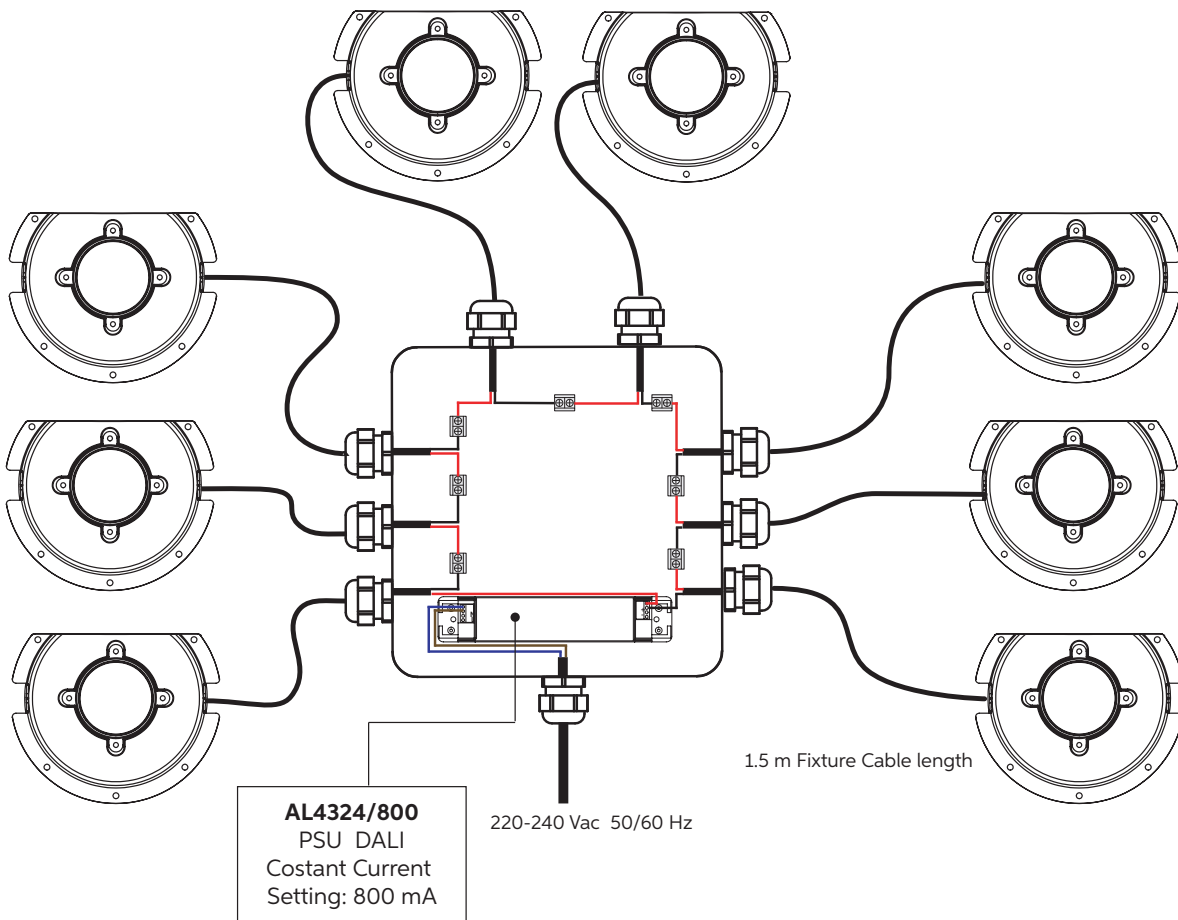

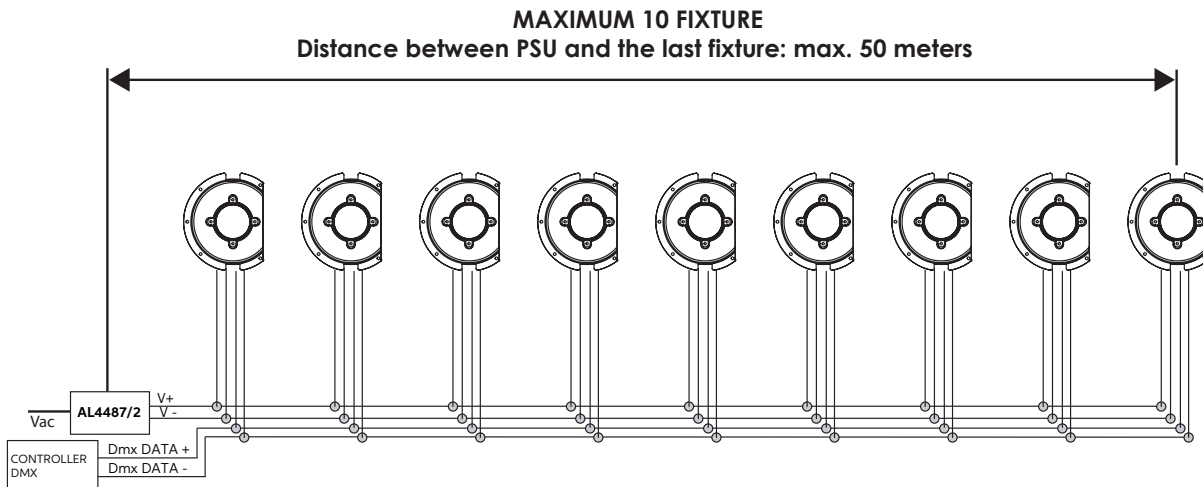

CABLE/CAVI	USE/UTILIZZO
BROWN / MARRONE	V+
BLUE / BLU	V-
WHITE / BIANCO	DMX DATA +
BLACK / NERO	DMX DATA -

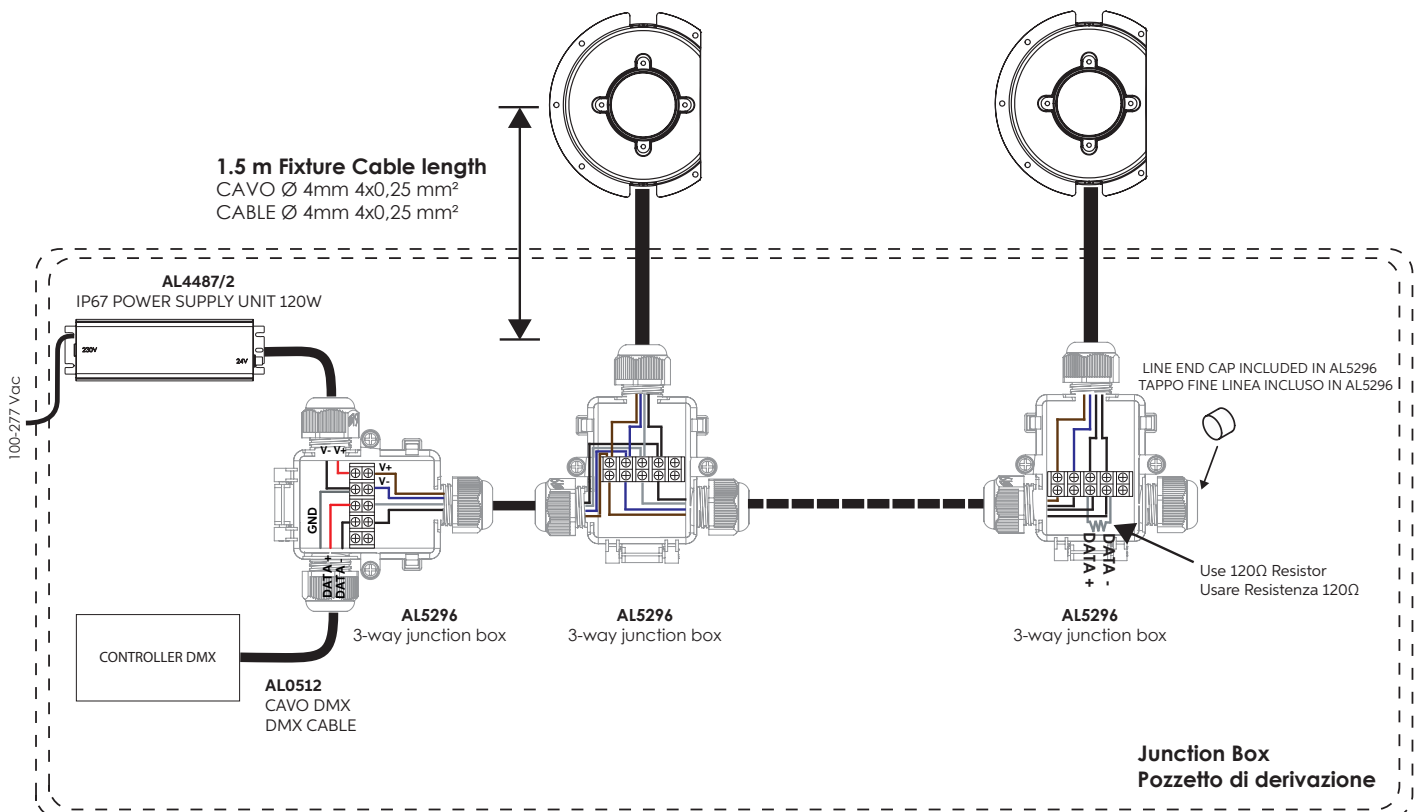

RGBW and DW

Mode	Channel	Function	Value	
Mode 4 channel - "RGBW 4ch"				
#1	1	0-100% Red	0-255	
	2	0-100% Green	0-255	
	3	0-100% Blue	0-255	
	4	0-100% White	0-255	
Mode 5 channel - "RGBW 5ch"				
#2	1	0-100% Red	0-255	
	2	0-100% Green	0-255	
	3	0-100% Blue	0-255	
	4	0-100% White	0-255	
	5	0-100% Dimmer	0-255	
Mode 6 channel - "RGBW 6ch"				
#3	1	0-100% Red	0-255	
	2	0-100% Green	0-255	
	3	0-100% Blue	0-255	
	4	0-100% White	0-255	
	5	0-100% Dimmer	0-255	
	6	No Strobo		0-5
		0-100% Strobo		6-250
100% Strobo		251-255		
Mode 4 channel - "RGBW MIX"				
#4	1	0-100% Red	0-255	
	2	0-100% Green	0-255	
	3	0-100% Blue	0-255	
	4	0-100% Calibrated White (affects RGB channels)	0-255	

DW (Dynamic White)

Mode	Channel	Function	Value
Mode 2 channel - "Dynamic White 2ch"			
#1	1	Warm White 100% / Cold White 0%	0-003
		Warm White 100% / Cold White 0%-100%	004-122
		Warm White 100% / Cold White 100%	123-132
		Warm White 100%-0% / Cold White 100%	133-251
		Warm White 0% / Cold White 100%	252-255
	2	DIMMER 0-100%	0-255
Mode 2 channel - "Separate White 2ch"			
#2	1	0%-100% Warm white	0-255
	2	0%-100% Cold white	0-255
Note: in absence of DMX signal the LEDs will remain ON .			

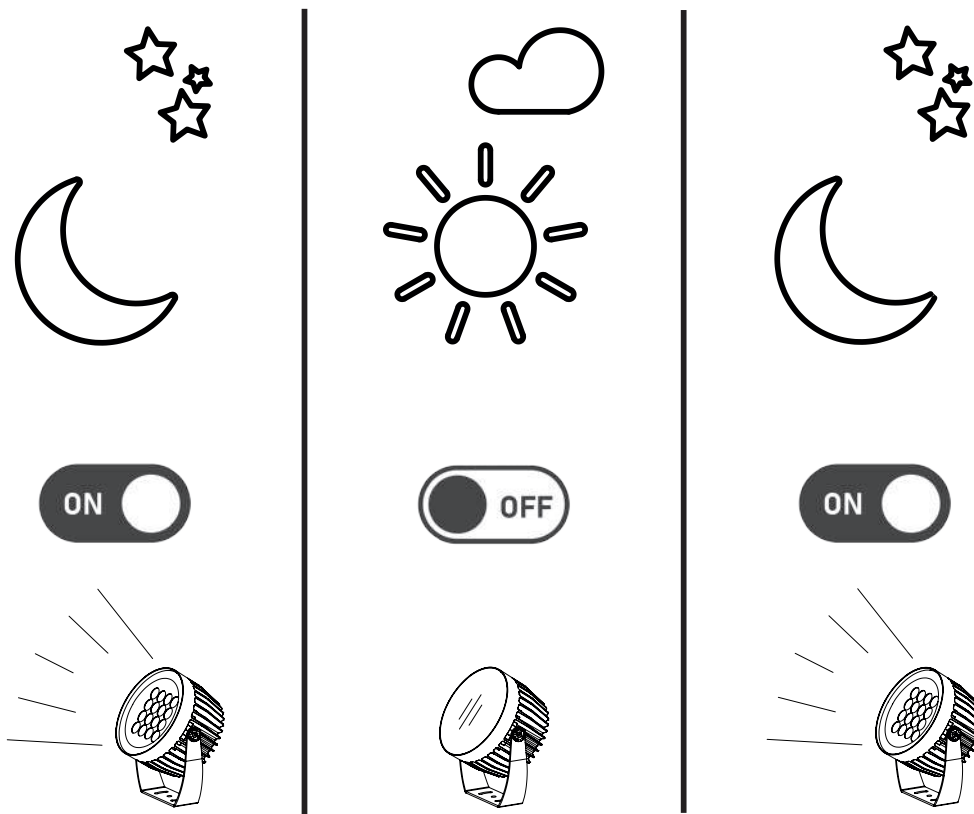

Note: Allowed operation only between sunset and sunrise

Nota: Accensione dell'apparecchio ammessa soltanto tra gli orari di tramonto e alba

Remote PSU / Alimentatori Esterni

Forward voltage led	Current	Code	Description	PSU ON/OFF IP20 1 PSU for (X) fixtures	PSU DALI IP20 1 PSU for (X) fixtures	PSU ON/OFF IP67 1 PSU for 1 fixtures	PSU ON-OFF AND DALI IP67 1 PSU for (X) fixtures	PSU 0-10V IP67 1 PSU for (X) fixtures
35V	250mA	AL5309 / AL5327	Moon Marine W	N/A	AL5295/250 (DALI) (1-3pcs)	AL5363/250 (DALI) (1pc)	N/A	N/A
35V	250mA	AL5311 / AL5325	Moon Recessed W / Moon Recessed Adjustable	N/A	AL5295/250 (DALI) (1-3pcs)	AL5363/250 (DALI) (1pc)	N/A	N/A
35V	350mA	AL5310 / AL5312 / AL5314	Moon W	AL5360/350 (ON/OFF) (1pc)	AL5295 (DALI) (1-3pcs)	AL5363/350 (DALI) (1pc)	AL5364/350 (1pc)	AL5364/350 (1pc)
3V	700mA	AL5317	Half Moon Recessed W	AL5360/700 (ON/OFF) (1-12pcs)	AL4324/700 (DALI) (1-9pcs)	N/A	AL5363/700 (4-14pcs)	AL5364/700 (4-14pcs)
3V	800mA	AL5309 / AL5327	Moon Marine Ultraspot W	AL5360/800 (ON/OFF) (1-12pcs)	AL4324/800 (DALI) (1-8pcs)	N/A	AL5364/800 (4-14pcs)	AL5364/800 (4-14pcs)
3V	800mA	AL5311 / AL5325	Moon Recessed Ultraspot W / Moon Recessed Adjustable Ultraspot W	AL5360/800 (ON/OFF) (1-12pcs)	AL4324/800 (DALI) (1-8pcs)	N/A	AL5364/800 (4-14pcs)	AL5364/800 (4-14pcs)
3V	900mA	AL5315/ AL5316 / AL5318	Half Moon W	AL5360/900 (ON/OFF) (1-12pcs)	AL4324/900 (DALI) (1-8pcs)	N/A	AL5364/900 (4-14pcs)	AL5364/900 (4-14pcs)
3V	900mA	AL5324 / AL5326	Half Moon Marine W	AL5360/900 (ON/OFF) (1-12pcs)	AL4324/900 (DALI) (1-8pcs)	N/A	AL5364/900 (4-14pcs)	AL5364/900 (4-14pcs)
3V	1000mA	AL5310 / AL5312 / AL5314	Moon Ultraspot W	AL5360/1000 (ON/OFF) (1-12pcs)	AL4324/1000 (DALI) (1-8pcs)	N/A	AL5364/1000 (4-14pcs)	AL5364/1000 (4-14pcs)